

# Boiler Tube Expander Order Form

*In order to help us serve you better, kindly email us the below details.*

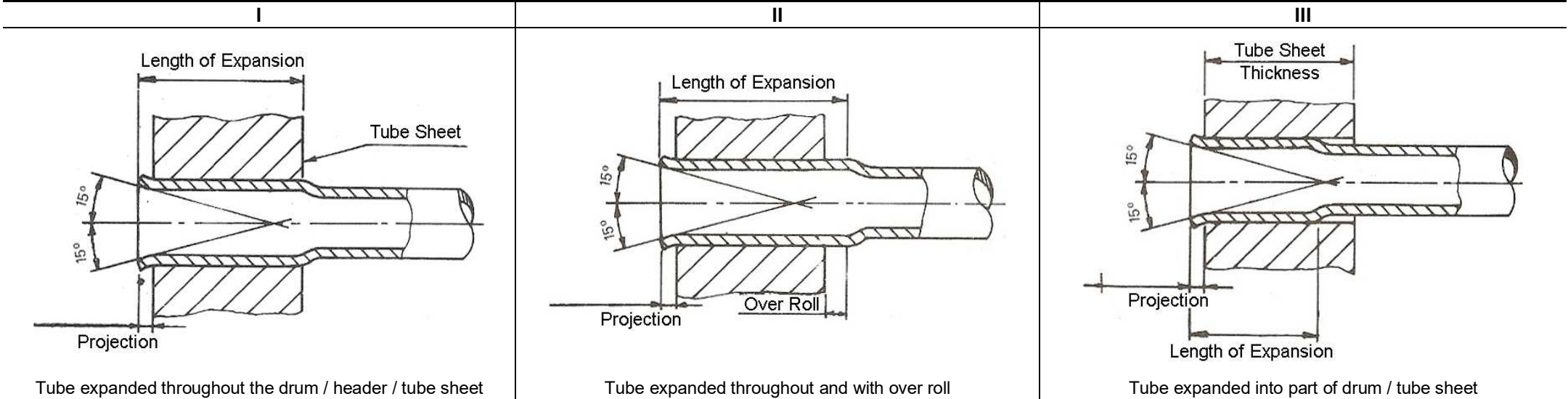

Sl. No.	Details	1	2	3	4	5	6	7
1	Material of Tube							
2	Tube O.D.							
3	Tube I.D.							
4	Tube Thk./Gauge							
5	Tube Sheet/Drum Thickness							
6	Tube Sheet Hole I.D.							
7	% Wall Thickness Reduction							
8	Length of Expansion							
9	Tube End Projection							
10	Bell Mouthing Required	Yes/No	Yes/No	Yes/No	Yes/No	Yes/No	Yes/No	Yes/No
11	Pitch Dimension							

\* Tolerance must be specified

Customer Name : \_\_\_\_\_

Address : \_\_\_\_\_

Conter Person's Name : \_\_\_\_\_

Designation : \_\_\_\_\_ Department : \_\_\_\_\_

Phone : \_\_\_\_\_ Hand Phone : \_\_\_\_\_

Email : \_\_\_\_\_ Preferred mode & time of contact : \_\_\_\_\_