

Instructions for installation and operation of

# KLINGER

Reflex Level Gauges K – D

asbestos-free

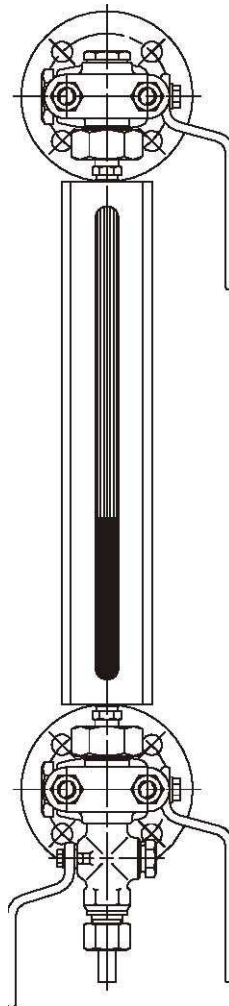

**dynaflex**<sup>®</sup>  
corporation

Chennai, INDIA

call +91 984 006 5966, +91 960 013 2488

email [support@dynaflex.asia](mailto:support@dynaflex.asia)

visit [www.dynaflex.asia](http://www.dynaflex.asia)

## Operating principle

Klinger reflex liquid level gauges serve to indicate the liquid level in boilers and vessels. The reflex glass held within the body and seals off the steam and water chamber at one side. The cover plate, in which the glass is held, contains a slot for observation of the liquid level.

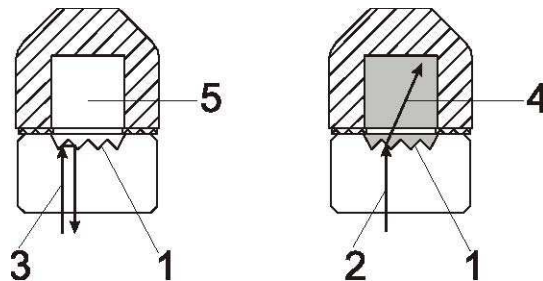

The Klinger reflex glass is provided with right angled grooves (1) on the side facing the liquid chamber. Because of the different indices of refraction, light rays (2) and (3) entering the chamber are absorbed in the liquid zone (4) but totally reflected in the steam (gas or air) space (5). The liquid space therefore appears black, the steam space silver-white. The level gauge is contained within Klinger level gauge Cocks which are sealed by a cylindrical plug and resilient packing sleeve on the principle of the Klinger AB cock.

The reflex liquid level gauge glass was invented in 1886 by Richard Klinger, the founder of the Klinger company.

## Installation

Drain cock 1.1 pressure tight with Klinger SIL sealing or graphite (21)

Level gauge body has to be placed in stuffing box 8.2 with ends (20)

Level gauge body (22) has to be adjusted and turned in required position

Level gauge body has to be screwed tight with stuffing box nut 9.2

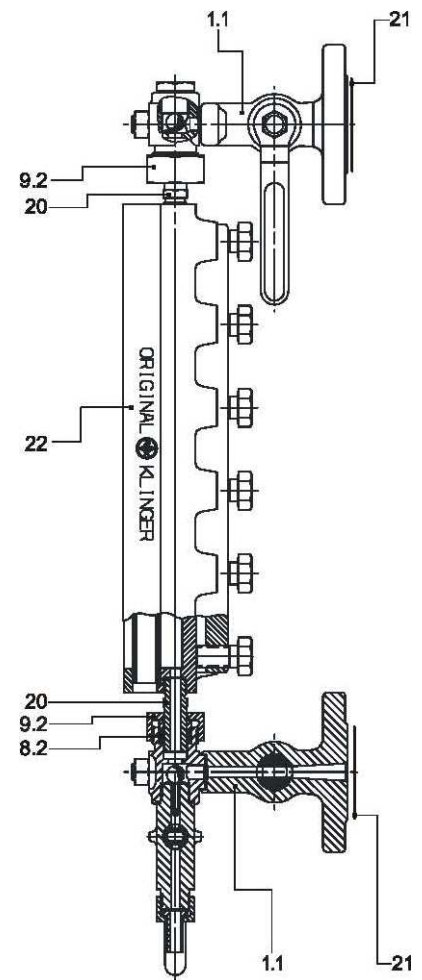

As gaskets we recommend Klinger jointing materials which, depending on quality, are suitable for all media and operating conditions. e.g.: K-Sil or Graphite

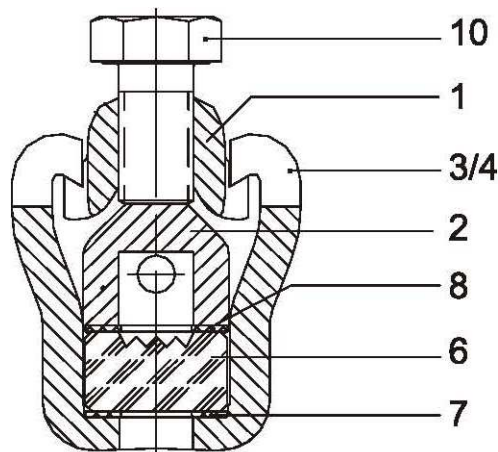

## Operating instructions

When the gauge is first commissioned (or after replacement of packing sleeves or gauge glass) the bolts (10) should be tightened with a torque spanner, starting from the centre of the gauge. Torque (cold) = 6mkp

Re-tighten nuts (13.2), union nuts (9.2) and – with the cock in the open position – the tightening nut (9.1).

Any leakage which occurs in service should be stopped by re-tightening as appropriated.

The gauge should be blow-down once daily: shut lower gauge cock, briefly blow through the upper gauge cock and briefly wash through the lower gauge cock by opening the drain cock. Repeat this procedure several times then turn gauge cocks once more to the operating position.

## Installing Instructions

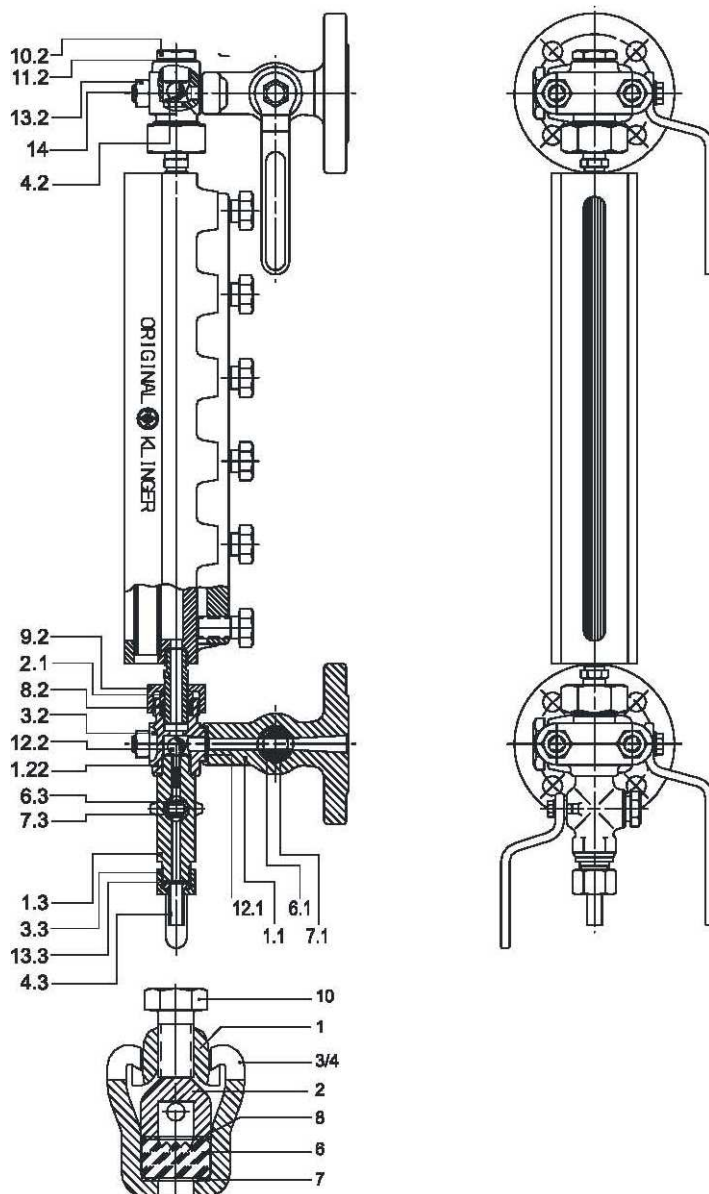

Naming of components	
1	Gauge cover
2	Centre piece
3/4	Wedge piece
6	Reflex glass
7	Cushion joint
8	Sealing joint
10	Hexagon headed screw
1.1	Gauge cock body
7.1	Cock plug
6.3	Packing sleeve
10.2	Joint ring
4.3	End tube
13.2	Hexagon nut
1.3	Drain cock body
9.1	Tightening nut
9.2	Union nut
12.1	Joint ring
12.2	Hexagon headed screw
1.21/22	Stuffing box body
2.1	Thrust ring
8.2	Gland ring 23,5/16x10
13.3	Joint ring
3.3	Union nut
14	Stud bolt
4.2	Pressure spring
11.2	Joint ring
3.2	Anti black spring

Shut gauge cock H – empty gauge S by opening the drain cock.

## Dismantling

- Remove hexagon nuts (13.2) and lift off stuffing-box heads A together with gauge S from gauge cocks H.
- Stock off union nut (9.2) and pull off stuffing-box heads A from end tubes.
- Place gauge S horizontally face downwards – loosen off tightening bolts (10).
- Push wedge piece (3) along the gauge body and lift out upwards.
- Lift off centre piece (2), reflex glass (6) and cushion joint (7).
- Carefully clean sealing surfaces of the cover (1) and centre piece (2).

## Assembly

- Insert new cushion joint (7) into the cover plate (1).
- Place new reflex glass on top (groove facing towards centre piece) followed by new sealing joint (8) and centre piece (2).
- Insert wedge piece (3) and push along gauge body to correct position.
- Tighten the hexagon bolts (10) to maximum torque of 60 Nm, working at opposite sides alternately.

## Instruction for storage

In accordance with DIN standard 3230, sheet 1, gauges should be stored in closed rooms with a nonaggressive atmosphere and be protected against dampness and dirt.

Spare parts like glasses, packing sleeves, gaskets, etc. must be stored in dry, cool rooms.

## Parts List for Klinger Reflex Gauge Type K – D

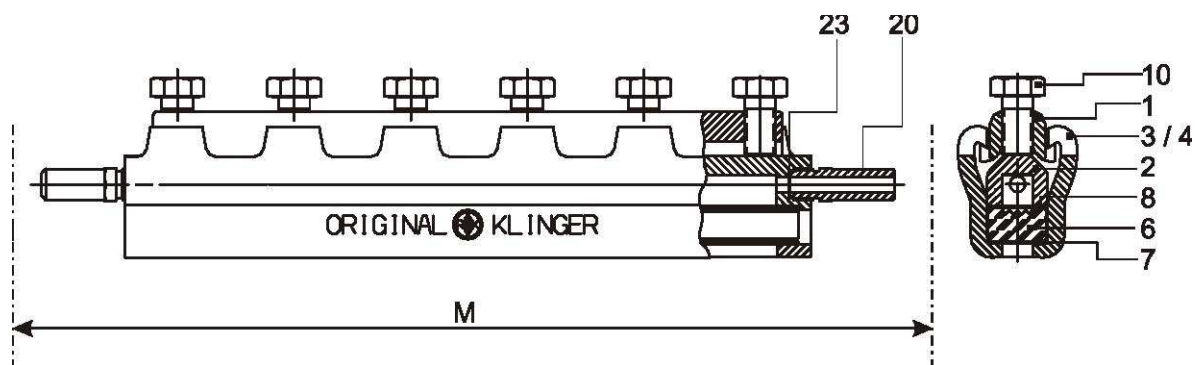

Part	Designation	Material
1	Body	Steel
2	Centre piece	Steel
3	Wedge piece	Steel
4	Tightening bolt	Steel
5	End tube	Steel
6	Reflex glass	Special glass
7	Cushion joint	K-Sil
8	Sealing joint	G-SLS
9	Joint ring 8/14x0,5 mm	Soft nickel

1 Body

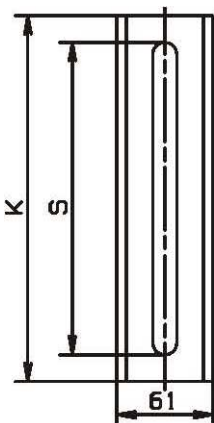

Size	K	G
III	178	143
IV	203	168
V	233	198
VI	263	228
VII	293	258
VIII	333	298
IX	353	318

2 Centre piece

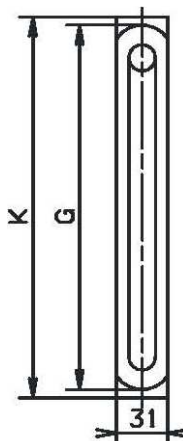

Size	K	G
III	178	167
IV	203	192
V	233	222
VI	263	252
VII	293	282
VIII	333	322
IX	353	342

3 Wedge piece

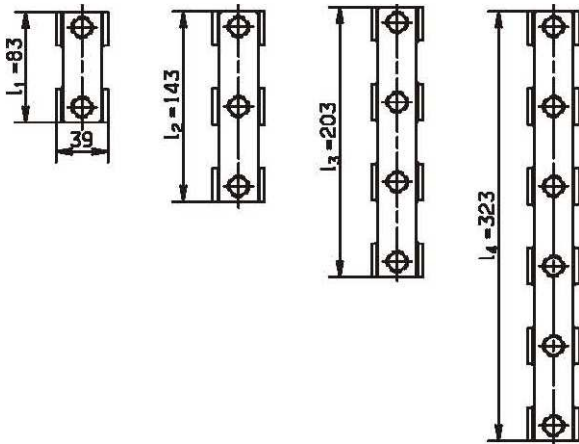

4 Tightening bolt

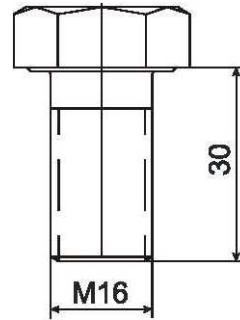

L = 42,5 – 47,5

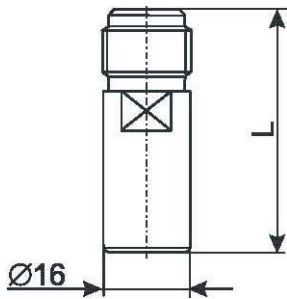

L = 52,5 – 72,5

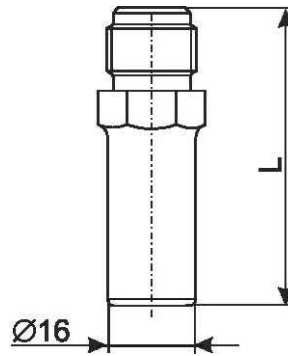

L < 77,5

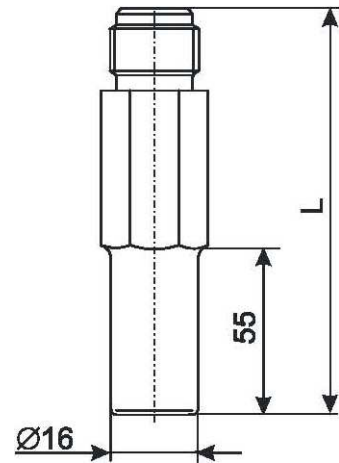

6 Reflex glass

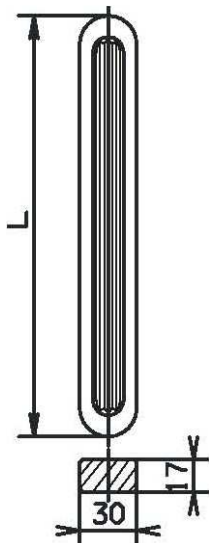

Size	L
III	165
IV	190
V	220
VI	250
VII	280
VIII	320
IX	340

7, 8 Cushion joint and Sealing joint

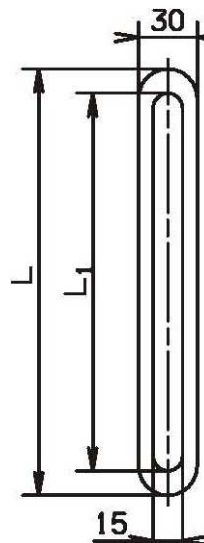

Size	L	L <sub>1</sub>
III	165	140
IV	190	165
V	220	195
VI	250	225
VII	280	255
VIII	320	295
IX	340	315



Chennai, INDIA

call **+91 984 006 5966, +91 960 013 2488** email [support@dynaflex.asia](mailto:support@dynaflex.asia) visit [www.dynaflex.asia](http://www.dynaflex.asia)